

MINI-EXCAVATORS

0.9 / 2.0 TONS

HD09V5
HD12VXE
HD17VXE
HD18V5
HD20N5

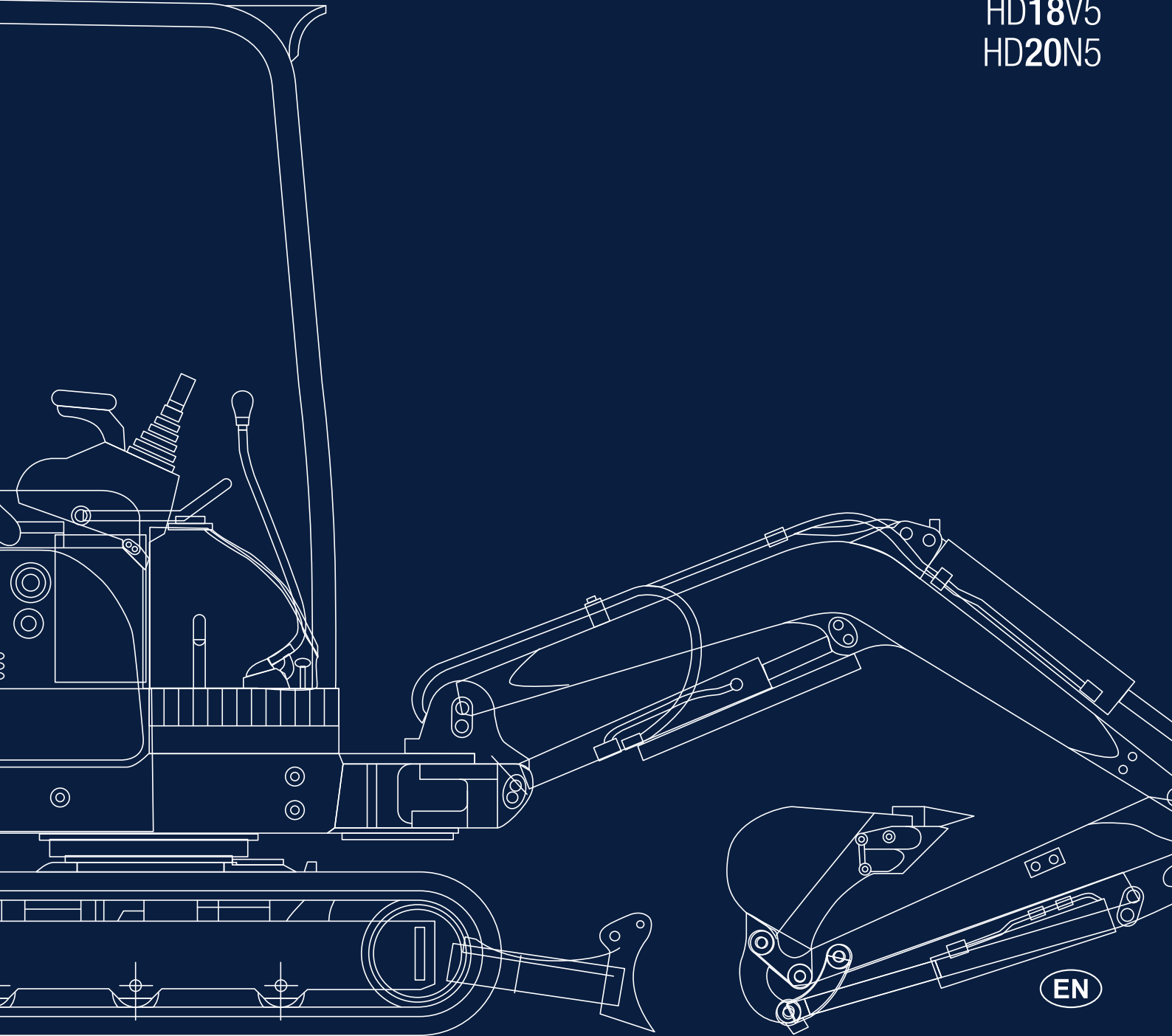

HD09V5

WHERE OTHERS CANNOT REACH

The new power-packed 9V5 excavator maximises operating efficiency by improving fuel consumption and reducing vibrations and noise. All this thanks to the adoption of the new 719 cc 3-cylinder engine with a power output of 7.4 kW at 2000 rpm and an optimised machine layout. Power and digging speed are assured when working in confined spaces: in small restructuring works, in operations of digging and maintenance of sewerage systems, also in tunnels where larger machines cannot operate, but also in the gardening and nursery sector.



The ultra-compact model HD09V5 micro excavator utilises the technology of higher class machines

The new design allows for an increase in traction during work and a longer life

Facilitated maintenance even if the dimensions are ultra-compact



COMPACT DIMENSIONS

Front turning radius with tilt: **950 mm**.

Machine width in narrow configuration: **720 mm**.

DOPPIA VELOCITÀ DI TRASLAZIONE

La doppia velocità di traslazione (1,8 / 3,2 km/h) consente una efficiente traslazione e la massima manovrabilità durante le operazioni in cantiere e spostamenti veloci. Il pedale della 2ª velocità è di facile utilizzo.



LED WORK LIGHT

The LED work light positioned on the arm perfectly lights-up the excavation area.



KUBOTA 7.4 KW DIESEL ENGINE

The three-cylinder Kubota engine calibrated at 7,4 Kw power output at 2000 rpm ensures comfort and reduced consumption thanks to the very low noise level and vibrations. With the new Stage V and Tier 4 Final engine, the 9V5 is ready to confirm the leadership of the Kato compact machines on the world market.



Swing motor

Despite the compact size of the machine, the swing motor is equipped with an automatic brake for blocking the turret in any position.

Greater production obtained thanks to the increased travel speed, the more efficient use of the swing motor and the lower centre of gravity.

Rotation inside the track gauge: to adapt to any situation

Thanks to the very small rear swing radius of 770 mm, during rotation the frame rotates within the track gauge of the tracks with the undercarriage widened and allows greater safety for both the machine and the operator. If the undercarriage is closed, access to confined spaces is facilitated.

The version with the auxiliary system for the demolition hammer and other accessories is available as an optional.

Low fuel consumption, low running costs and facilitated maintenance ensure higher profit. High reliability and the long life of the machine are ensured by the optimised design and the low swing speed of the combustion engine.



INSPECTION AND MAINTENANCE

The fully openable engine hood facilitates visibility of most of the engine and allows easy access to the various components for inspection and maintenance operations. The battery is low maintenance. The resin fuel tank has been designed to prevent rust and the aluminium radiator ensures efficient heat exchange and high resistance to corrosion. The large air filter increases maintenance intervals. The new design of the 9V5 satisfies facilitated maintenance and the legendary reliability of the KATO machines.



THE ROLLERS

Rollers with double external side support reduce wear on the tracks, improve load distribution and increase operating stability.

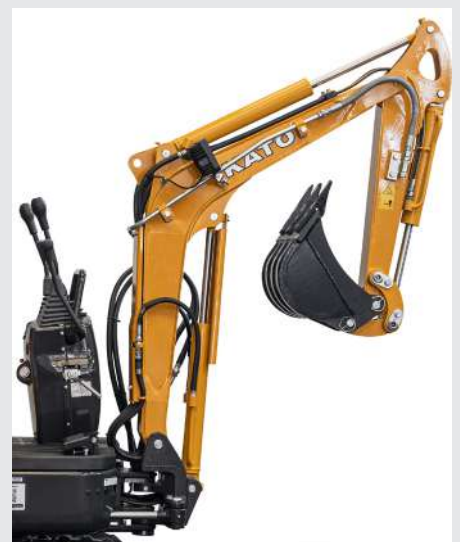

WORK EQUIPMENT

The considerable geometry of movement of the arm and the minimum distance between bucket and dozer blade, allow digging even close to the dozer blade. The lifting cylinder has a strong metal guard and all feed pipes to the bucket and swing cylinders are well protected.



COMFORT AND SAFETY

High operator comfort: low vibrations and low noise. Human interface improved with the digital hour meter. Designed around the operator, the driver's seat is comfortable thanks to the adjustable seat and ergonomic controls. The driver's seat can be accessed from both sides. The HD09V5 is equipped with DCS (Direct Control System) controls that ensure maximum precision. The control pedals of the auxiliary circuit and the swing are separate. Both pedals can be folded or covered, thus increasing space at the operator's feet. The control panel is easy to read. A safety device controls access to the driver's seat: if the lever is raised, it prevents arm movements. A front bar ensures the operator a safe and protected driver's seat; at the back the machine is well protected by cast iron bumpers.

Variable gauge undercarriage

Thanks to the extendible frame (720 - 950 mm), the HD09V5 ensures high versatility. Access to very limited space is allowed and by widening the undercarriage in just a few seconds, a high level of safety and significant operating stability are obtained.



DOUBLE-PIN BLADE EXTENSION

The double-pin blade extension system facilitates and simplifies installation, ensuring greater strength during use.

GREAT STABILITY

Better machine stability thanks to an equal distribution of weights and the larger front blade.

TECHNICAL SPECIFICATIONS

Engine	Kubota D722-E4B
No. of cylinders / displacement	3 / 719 cc
Rated output	7.4 kW / 2000 rpm
Machine weight with canopy (std arm)	984 kg
Operating weight with canopy (std arm)	1059 kg
Max. digging depth	1570 / 1770 mm (with long arm)
Minimum front turning radius	1220 / 1320 mm (with long arm)
Bucket digging force	1060 kgf
Standard bucket width	350 mm
Standard bucket capacity	0.022 m ³

HD12VXE

SMALL AND POWERFUL

The HD12VXE mini excavator is brand new: small enough to pass through doors, sturdy enough to do jobs of higher category models. An exceptional machine. With its 9.4 kW engine and digging depth of 2010 mm, it can handle heavy work in the most challenging conditions with ease.





REAR FRAME IN TRACK GAUGE

During rotation, the frame rotates within the track gauge of the tracks with the undercarriage widened, allowing greater safety for the machine and the operator. If the undercarriage is closed, access to very confined spaces is facilitated. With an 870 mm width and a reclining rollbar, this machine becomes ideal for internal restructuring work.

COMPACT SIZE

Excellence in small size and high power. The HD12VXE can access previously inaccessible spaces, inside buildings or it can pass through buildings to reach hard-to-access internal gardens and courtyards.

DOUBLE TRAVELLING SPEED

The double travelling speed (2.3 / 4.0 km / h) allows fast on-site displacements and maximum manoeuvrability.



Minimum front turning radius with tilt
rh = 1291 mm, lh = 1383 mm
Front turning radius = 1540 mm
Rear turning radius = 552 mm

Machine weight of 1180 kg,
ideal for transport
with trucks category
up to 3.5 tons



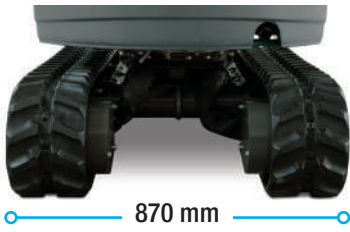

870 mm

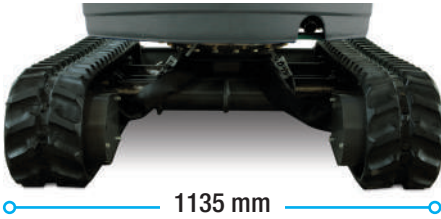

1135 mm

VARIABLE GAUGE UNDERCARRIAGE

Thanks to the variable gauge undercarriage (870 - 1135 mm) the HD12VXE ensures significant safety and operating stability during side digging and lifting operations on sites with minimal manoeuvrability spaces, on uneven surfaces or in the presence of sharp slopes. The circular pipe improves outreach sliding and decreases clearance.

SAFETY

The TOPS certified rollbar canopy (the optional FOPS cover can be supplied on request) ensures maximum operating visibility. Arm movements are cushioned by the Anti-Shock valve of the hydraulic circuit. During lifting of the 1st arm, the stop shock at limit switch of the arm is limited by the cylinder shock-absorbing system. The self-braking swing motor prevents accidental movements of the arm during machine transport or parking. The swing of the arm is controlled by means of the left joystick. The hydraulic circuit control pedal is fitted with a tilting protection with the double function of footrest and block to keep the control engaged.



The HD12VXE is able to pass through a door with less than 90 cm clearance. In addition, the rollbar can be disassembled in a few minutes to facilitate passing under minimum heights.

90 cm



DOUBLE-PIN BLADE EXTENSION

The double-pin blade extension system facilitates and simplifies installation, ensuring greater strength during use.





ACCESSIBILITY AND FACILITATED MAINTENANCE

The HD12VXE fits a vertical opening hood facilitating accessibility and visibility of most of the engine and allowing easy access to the various components for daily inspection (oil-filters-belts) and maintenance. The battery requires low maintenance. The large diesel tank allows the machine to be used for the whole day, is subjected to normal use. It is easily accessed for refuelling and protected with a lockable cap. Inspection of the operating hydraulic pressures is facilitated by the pressure intakes on the pumps.

YANMAR 9.4 KW DIESEL ENGINE

The 3-cylinder engine has a low rotation speed and the utilisation index is reduced to improve durability and reliability over time. The high-capacity air filter consists of a double cartridge which reduces maintenance and increases engine reliability. The fuel circuit features a diesel filter with water separator, ensuring a longer engine life. The high engine efficiency combined with an advanced hydraulic system, ensures reduced fuel consumption, less noise and limits polluting emissions according to the EPA Tier 4 regulation requirements.

THE HYDRAULIC CIRCUIT

It uses two variable displacement pumps with Straight Travel system on the blade section, and an autonomous gear pump for the servo controls, ensuring a constant balance between operating speed and work forces. Precise and simultaneous manoeuvres are ensured without loss of power or drop in engine speed. The HD12VXE is able to travel at the same time as manoeuvre the blade, without losing trajectory linearity.

THE AUXILIARY HYDRAULIC CIRCUIT

For the use of hydraulic accessories such as the demolition hammer, shears, hydraulic grippers, augers, the auxiliary hydraulic circuit is standard fitted up to the 2nd arm. A specific diverter makes it possible to select the function in a simple or double acting manner.



COMFORT AND SAFETY

The driver's seat is particularly comfortable, thanks to the enveloping and adjustable seat, the adjustable wrist support and the ergonomic layout of the controls. It is standard equipped with servo-assisted joysticks which ensure maximum precision. Two safety levers control access to the driver's seat from both sides, and if raised, they inhibit all work controls and machine travel. The multifunction analogue monitor - hour meter, fuel level, oil temperature with luminous indicators - is intuitive and facilitates the task of less experienced operators, improving their productivity.



WORK LIGHT

A work light positioned on the arm perfectly lights-up the excavation area.

TECHNICAL SPECIFICATIONS

Engine	Yanmar 3TNM68
No. of cylinders / displacement	3 / 784 cc
Rated output	9.4 kW / 2200 rpm
Machine weight with rollbar	1180 kg
Operating weight with rollbar	1255 kg
Max. digging depth	2010 mm
Minimum front turning radius	1540 mm
Bucket digging force	1210 kgf
Standard bucket width	400 mm
Standard bucket capacity	0.036 m ³

HD17VXE

WHERE OTHERS CANNOT REACH

The ultra-compact model HD17VXE mini excavator utilises the technology of higher class machines. Power and speed of digging are assured when working in confined spaces: in small restructuring works, in operations of digging and maintenance of sewerage systems, also in tunnels where larger machines cannot operate, but also in the gardening and nursery sector.

Fast on-site displacements and maximum manoeuvrability



Significant safety and operating stability during side digging and lifting operations in confined spaces or on particularly rugged terrain or on sloping terrain

MINI-EXCAVATORS 0.9 / 2.0 TONS

10.5 KW 3TNV70 YANMAR DIESEL ENGINE

The 3-cylinder engine has a low rotation speed and the utilisation index is reduced to improve durability and reliability over time. The high-capacity air filter consists of a double cartridge which reduces maintenance and increases engine reliability. The fuel circuit features a diesel filter with water separator, ensuring a longer engine life. The high engine efficiency combined with an advanced hydraulic system, ensures reduced fuel consumption, less noise and limits polluting emissions according to the EPA Tier 4 regulation.

DOUBLE TRAVELLING SPEED

The double travelling speed (2.1 / 4.2 km / h) allows fast on-site displacements and maximum manoeuvrability.



COMFORT AND SAFETY

The workstation is comfortable thanks to the adjustable and sprung seat, horizontal adjustment, adjustable backrest and ergonomic layout of the controls. The standard version is equipped with pilot-operated joysticks that ensure maximum precision. The safety levers control access to the driver's seat and, if raised, inhibits all work controls and machine travel. The instrumentation console is simple and intuitive. A document holder is positioned behind the seat.

WORK EQUIPMENT

For the use of various hydraulic accessories, the auxiliary hydraulic circuit is standard fitted up to the 2nd arm. The system uses a valve for the direct return of the oil to the hydraulic tank. A pedal locking device ensures the use of manually controlled hydraulic tools. The long arm version is available as an option to increase excavation depth (max 2350 mm). The control with second speed button is supplied.



REAR FRAME IN TRACK GAUGE

During rotation, the frame rotates within the track gauge of the tracks with the undercarriage widened, allowing greater safety for the machine and the operator. If the undercarriage is closed, access to confined spaces is facilitated. It is available with rubber tracks and 4-post canopy with TOPS-FOPS protection (complying with EEC safety regulations).



OPERATING FLEXIBILITY

When the machine is operating with the undercarriage closed, the two extendable sections of the blade can be easily stowed behind the blade itself. A lever via a function selector controls the movement of the blade or the expansion of the undercarriage.



MAXIMUM VERSATILITY

The particular geometry of the arm and the movement together with the minimum distance between bucket and dozer blade, allow digging and loading of large materials even close to the dozer blade.

SOLIDITY AND STABILITY

In addition to helping reduce the specific pressure on the ground, the long undercarriage (1570 mm) ensures great frontal stability with the blade raised. The travel unit is integrated into the width of the tracks.



THE HYDRAULIC CIRCUIT

It uses two variable displacement pumps and two gear pumps, ensuring a constant balance between operating speed and work forces. Precise and simultaneous manoeuvres are ensured without loss of power or drop in engine speed. The HD17VXE is able to travel at the same time as performing work manoeuvres, without losing trajectory linearity.



ACCESSIBILITY AND FACILITATED MAINTENANCE

The side opening engine hood facilitates accessibility and visibility of most of the engine and allows easy access to the various components for daily inspection (oil-filters-belts) and maintenance. The battery requires low maintenance. Refuelling with diesel is allowed by comfortable and easy access with a key cap. Inspection of the operating pressures is facilitated by the quick couplings on the pumps.

Safety

During lifting of the 1st arm, the stop shock at limit switch of the arm is limited by the cylinder shock-absorbing system

A similar system comes into action also when the swing bearing rotates

Arm movements are cushioned by the Anti-Shock valve of the hydraulic circuit

The canopy ensures maximum operating visibility

The self-braking swing motor prevents accidental movements in the absence of the operator

The control pedals of the auxiliary circuit and tilt are separated and reinforced by sturdy guards with footrest function



VARIABLE GAUGE UNDERCARRIAGE

Thanks to the extendable frame (980 - 1300 mm) the HD17VXE ensures considerable safety and operating stability during side digging and lifting operations in confined spaces or on particularly rugged terrain or on sloping terrain. Work sites with reduced manoeuvring spaces are no longer a problem.

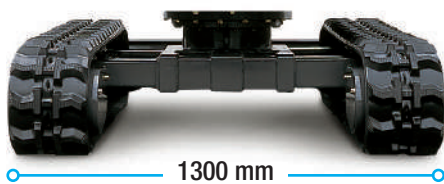
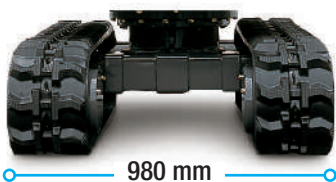

TECHNICAL SPECIFICATIONS

Engine	Yanmar 3TNV70
No. of cylinders / displacement	3 / 854 cc
Rated output	10.5 kW / 2300 rpm
Machine weight	1615 kg
Operating weight	1690 kg
Max. digging depth	2350 mm (with long arm)
Minimum front turning radius	1580 mm (with long arm)
Bucket digging force	1600 kgf
Standard bucket width	400 mm
Standard bucket capacity	0.044 m ³

HD18V5

MINI EXCAVATOR, GREAT PERFORMANCE

KATO has developed the HD18V5 mini excavator equipping it with a YANMAR 3TNV74 engine which, with its 993 cc displacement, has a calibration power of 10.5 kW at 2300 rpm.

HD18V5's operating weight is 1855 kg with rubber track. The standard configuration features the front blade with variable widths 990 mm / 1300 mm and a 400 mm bucket.

MAXIMUM DIGGING RADIUS:
3820 MM
MAXIMUM VERTICAL
DIGGING DEPTH:
1730 MM



STANDARD BUCKET
Width of 400 mm and
capacity of 0.04 m³

LED LIGHT
incorporated
into the arm

BLADE
Width of 990 mm / 1300 mm

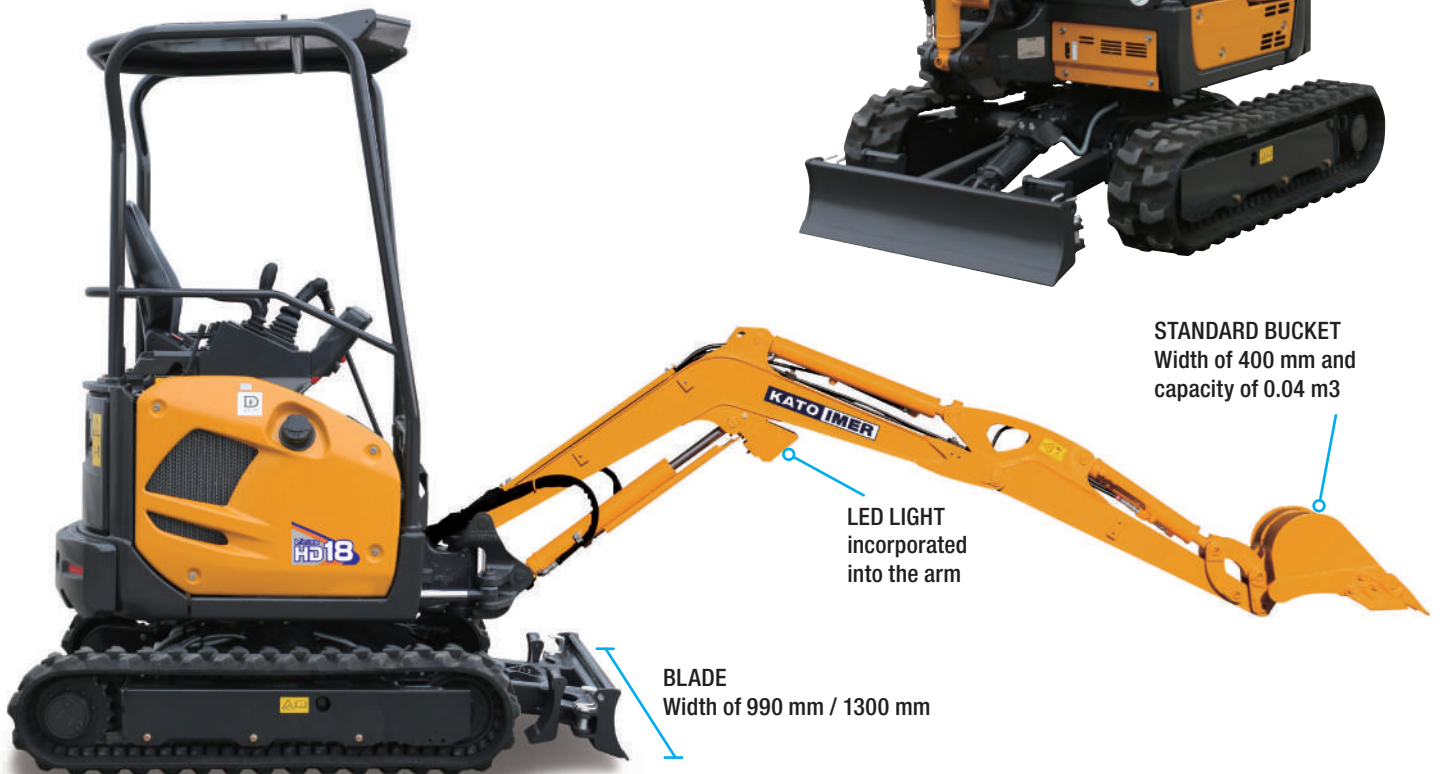

MINI-EXCAVATORS 0.9 / 2.0 TONS



YANMAR 3TNV74 ENGINE

4-stroke, 993 cc, 3 ϕ 74 x 77 mm cylinder, water cooled engine. Compact, light and simple. High torque and power, fuel consumption is 273 g/kW-h. Minimised pollution emissions and facilitated maintenance with reduced maintenance and operating costs.



HYDRAULIC SYSTEM

All machine operations are managed by joystick lever. The system consists of 3 pumps, 17.2 x 2 + 12 L / min, for a pressure of 20.6 MPa (210 kg / cm²).



DRIVER'S SEAT

The driver's seat is spacious and enveloping, with a wrist support and display with machine function control instrumentation. The canopy has a FOPS protection against the falling of objects from height and a TOPS and ROPS protection against tipping and rolling.



STANDARD BUCKET AND BLADE

The 400 mm bucket has a digging force of 1670 kgf and a capacity of 0.04 m³. The blade is 990 mm wide and can be extended to 1300 mm.



990 mm



VARIABLE GAUGE UNDERCARRIAGE

Thanks to the 990 - 1300 mm extendable frame, the HD18V5 significantly increases stability during side digging and lifting, even on particularly uneven surfaces.



1300 mm

TECHNICAL SPECIFICATIONS

Engine	YANMAR 3TNV74
No. of cylinders / displacement	3 / 993 cc
Rated output	10.5 kW / 2300 rpm
Machine weight	1780 kg
Operating weight	1855 kg
Max. digging depth	2190 mm
Minimum turning radius	1480 / 650 mm (front / rear)
Bucket digging force	1670 kgf
Standard bucket width	400 mm
Standard bucket capacity	0.04 m ³

HD20N5

INNOVATION AND OPERATIONAL COMFORT

An ideal mini-excavator for working in confined spaces and rough terrain, thanks to its extendable frame (990 to 1300 mm) that allows for high versatility and operational stability. With an operating weight of 1895 kg (canopy version) and 2045 kg (cabin version), dual travel speeds (2.1-4.0 km/h) and a digging depth of 2440 mm, the HD20N5 is at the top of its class.

MAXIMUM DIGGING RADIUS:
3970 MM
MAXIMUM VERTICAL
DIGGING DEPTH:
2020 MM



AVAILABLE WITH CABIN

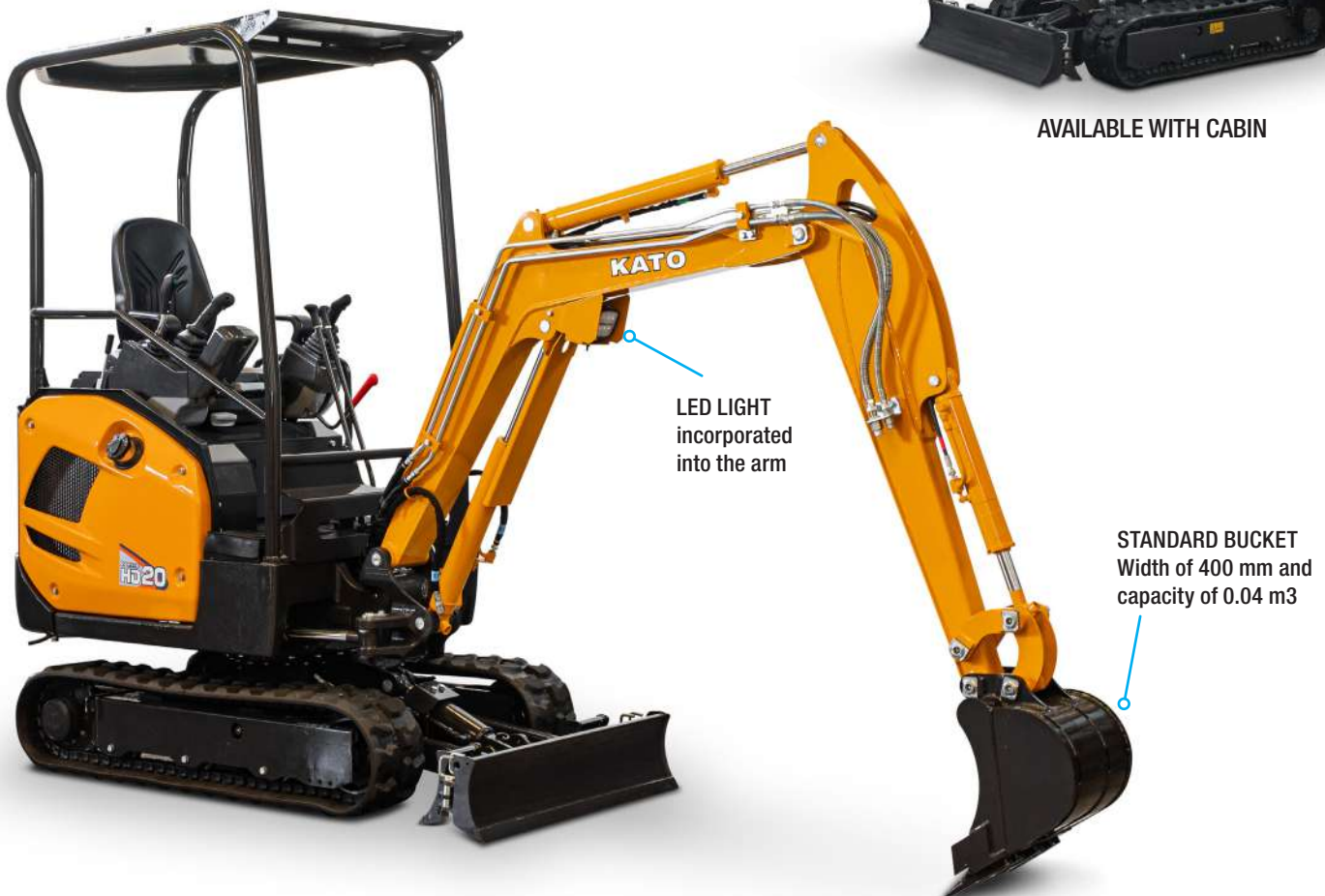

LED LIGHT
incorporated
into the arm

STANDARD BUCKET
Width of 400 mm and
capacity of 0.04 m3



YANMAR 3TNV74 ENGINE

4-stroke, 993 cc, 3 ϕ 74 x 77 mm cylinder, water cooled engine. Compact, light and simple. High torque and power, fuel consumption is 273 g/kW-h. Minimised pollution emissions and facilitated maintenance with reduced maintenance and operating costs.



HYDRAULIC SYSTEM

All machine operations are managed by joystick lever. The system consists of 3 pumps, 17.2 x 2 + 12 L / min, for a pressure of 20.6 MPa (210 kgf / cm²).



DRIVER'S SEAT

The driver's seat is spacious and enveloping, with a wrist support and display with machine function control instrumentation. The canopy has a FOPS protection against the falling of objects from height and a TOPS and ROPS protection against tipping and rolling.



VARIABLE GAUGE UNDERCARRIAGE

Thanks to the 990 - 1300 mm extendable frame, the HD20N5 significantly increases stability during side digging and lifting, even on particularly uneven surfaces.



DOUBLE-PIN BLADE EXTENSION

The double-pin blade extension system facilitates and simplifies installation, ensuring greater strength during use.

TECHNICAL SPECIFICATIONS

Engine	YANMAR 3TNV74
No. of cylinders / displacement	3 / 993 cc
Rated output	10.5 kW / 2300 rpm
Machine weight Canopy / Cabin	1820 / 1970 kg
Operating weight Canopy / Cabin	1895 / 2045 kg
Max. digging depth	2440 mm
Minimum turning radius	1550 / 980 mm (front / rear)
Bucket digging force	1670 kgf
Standard bucket width	400 mm
Standard bucket capacity	0.04 m ³

specifications

	HD09V5	HD12VXE
GENERAL PERFORMANCE		
Standard bucket capacity	0.022 m ³	0.036 m ³
Standard bucket width	350 mm	400 mm
Machine weight	984 kg	1180 kg
Operating weight	1059 kg	1255 kg
Transport dimensions	2780 x 765 x 2330 mm	3110 x 870 x 2280 mm
Gradeability	30°	30°
Ground contact pressure	28,6 kPa (0,29 kgf / cm ²)	26.2 kPa (0.27 kgf / cm ²)
Minimum ground clearance	160 mm	170 mm
ENGINE		
Model	Kubota D722-E4B	Yanmar 3TNM68
No. of cylinders and engine size	3 / 719 cc	3 / 784 cc
Bore for stroke	67 x 68 mm	68 x 72 mm
Rated output (ISO 1585)	7.4 kW / 2000 rpm	9.4 kW / 2200 rpm
Fuel consumption	252 g / kWh	260 g / kWh
Engine oil pan capacity	3.2 L (Maximum level)	2.5 L (Maximum level)
ELECTRICAL EQUIPMENT		
Voltage	12 V	12 V
Battery	12 V - 37 Ah	12 V - 45 Ah
Alternator	12 V - 14 A	12 V - 20 A
Starter motor	12 V - 1.2 kW	12 V - 1.2 kW
HYDRAULIC SYSTEM		
Pumps maximum flow rate	22.4 L / min	13.2 L / min x 2
Max Pressure / Setting	16 MPa (163 kgf / cm ²)	20.6 MPa (210 kgf / cm ²)
Control	DCS (Direct Control System)	joystick
Number of pumps	2	3
DOUBLE ACTION HYDRAULIC CIRCUIT FOR ACCESSORIES		
Maximum flow rate	22.4 L / min	26 L / min
Max setting pressure	16 MPa (163 kgf / cm ²)	20.6 MPa (210 kgf / cm ²)
END-OF-STROKE CUSHIONING		
Arm cylinder	rod fully extended	rod fully extended
SLEWING SYSTEM		
Slewing speed	8.0 min ⁻¹	8.5 min ⁻¹
Turret braking	automatic multi-disc brake	automatic multi-disc brake
BUCKET PERFORMANCE		
Bucket digging force (ISO 6015)	10.4 kN (1060 kgf)	11.86 kN (1210 kgf)
Bucket accumulation force (ISO 6015)	6.1 kN (620 kgf)	7.84 kN (800 kgf)
LOWER FRAME		
Undercarriage length	1220 mm	1339 mm
Extendible undercarriage	720 / 950 mm	870 / 1135 mm
Tracks width	180 mm	200 mm
Lower / upper rollers per side	2	3
Track tension	with grease pump	with grease pump
Blade dimensions (wxh) mm	720 / 970 mm x 240 mm	870 / 1135 mm x 230 mm
Upward movement	220 mm	230 mm
Downward movement	150 mm	210 mm
TRAVEL SYSTEM		
Travel speed (1a / 2a)	1.8 / 3.2 km / h	2.3 / 4.0 km / h
CAPACITY		
Fuel tank capacity	11 L	12.5 L
Hydraulic tank capacity	9.6 L	17 L
Hydraulic circuit total capacity	14 L	26 L
Engine coolant	2.7 L	3.6 L
EXCAVATION ARM		
Right swing angle	90°	80°
Left swing angle	50°	50°
OTHER DATA		
Sound power level Lwa	90 dB	93 dB

HD17VXE

HD18V5

HD20N5

0.044 m ³	0.04 m ³	0.04 m ³
400 mm	400 mm	400 mm
1615 kg	1780 kg	1820/1970 kg (Canopy/Cabin)
1690 kg	1855 kg	1895/2045 kg (Canopy/Cabin)
3380 x 980 x 2330 mm	3450 x 990 x 2390 mm	3580 x 990 x 2400 mm
30°	30°	30°
25.6 kPa (0.26 kgf / cm ²)	30 kPa (0.30 kgf / cm ²)	30 kPa (0.30 kgf / cm ²)
175 mm	170 mm	170 mm
Yanmar 3TNV70	Yanmar 3TNV74	Yanmar 3TNV74
3 / 854 cc	3 / 993 cc	3 / 993 cc
70 x 74 mm	74 x 77 mm	74 x 77 mm
10.5 kW / 2300 rpm	10.5 kW / 2300 rpm	10.5 kW / 2300 rpm
272 g / kWh	273 g / kWh	273 g / kWh
3.8 L (Maximum level)	3.8 L (Maximum level)	3.8 L (Maximum level)
12 V	12 V	12 V
12 V - 45 Ah	12 V - 45 Ah	12 V - 45 Ah
12 V - 20 A	12 V - 20 A	12 V - 20 A
12 V - 1.1 kW	12 V - 1.1 kW	12 V - 1.1 kW
17.2 L / min x 2 + 12 L / min	17.2 L / min x 2 + 12 L / min	17.2 L / min x 2 + 12 L / min
20.6 MPa (210 kgf / cm ²)	20.6 MPa (210 kgf / cm ²)	20.6 MPa (210 kgf / cm ²)
joystick	joystick	joystick
3	3	3
29.2 L / min	29.2 L / min	29.2 L / min
20.6 MPa (210 kgf / cm ²)	20.6 MPa (210 kgf / cm ²)	20.6 MPa (210 kgf / cm ²)
rod fully extended	rod fully extended	rod fully extended
9.4 min ⁻¹	8.5 min ⁻¹	8.5 min ⁻¹
automatic multi-disc brake	automatic multi-disc brake	automatic multi-disc brake
15.7 kN (1600 kgf)	16.4 kN (1670 kgf)	16.4 kN (1670 kgf)
9.35 kN (950 kgf)	9.6 kN (980 kgf)	8.2 kN (840 kgf)
1570 mm	1570 mm	1570 mm
980 / 1300 mm	990 / 1300 mm	990 / 1300 mm
230 mm	230 mm	230 mm
3	3	3
with grease pump	with grease pump	with grease pump
980 / 1300 mm x 235 mm	990 / 1300 mm x 235 mm	990 / 1300 mm x 235 mm
230 mm	300 mm	300 mm
340 mm	230 mm	230 mm
2.1 / 4.2 km / h	2.1 / 4.0 km / h	2.1 / 4.0 km / h
20 L	22 L	22 L
19 L	16 L	16 L
23 L	21 L	21 L
3.6 L	3.5 L	3.5 L
80°	70°	70°
55°	55°	55°
93 dB	93 dB	93 dB

equipment

	HD09V5	HD12VXE	HD17VXE	HD18V5	HD20N5
SUPPORT FRAME					
Rubber tracks (width mm)	180	200	230	230	230
Attachment points for lifting-anchoring-towing and lubrication of the tilt cylinder foot	std	std	std	std	std
Expandable undercarriage (mm) - Filling blade with extensions	720-970	870-1135	980-1300	990-1300	990-1300
ENGINE					
Two-phase dry air filter with visual clogging indicator	std	std	std	std	std
Electric pre-heating device	std	std	std	std	std
Fuel water separator	std	std	std	std	std
Diesel tank with bleeding cap	plastic material	plastic material	plastic material	plastic material	plastic material
Engine speed adjustment	std	std	std	std	std
ELECTRICAL SYSTEM					
12V battery with fuse box	std	std	std	std	std
DRIVING SEAT					
Longitudinal adjustment bucket seat, vinyl covering	std	std	std	std	std
Fabric seat	-	-	-	-	opt
Non-slip rubber mat	std	std	std	std	std
Wrist support	-	std	std	std	std
Seatbelt	with reel	with reel	std	with reel	with reel
High speed control	std	std	std	std	std
Travel control pedals	-	std	std	-	-
INSTRUMENTS AND CONTROL DEVICES					
Worklight switch; auxiliary system control	std	std	std	std	std
Aux. system proportional control switch on joystick	-	-	-	std	std
Water temperature control instrument	-	digital	analogue	analogue	analogue
Fuel level control instrument	visual	digital	analogue	analogue	analogue
Hour meter	std	std	std	std	std
Warning light for: pre-heating, engine oil pressure, battery charge, water temperature	std	std	std	std	std
High gear indicator light	-	-	-	std	std
Engine alarm device in case of overheating or low oil pressure	std	std	std	std	std
Travel alarm	-	-	-	opt	opt
CANOPY VERSION					
FOPS protection against falling objects	-	opt	std	std	std
TOPS protection against tipping	-	std	-	-	-
TOPS and ROPS protection against tipping and rolling	opt	-	std	std	std
CABIN VERSION					
TOPS and ROPS protection against tipping and rolling	-	-	-	-	std
FOPS grid against falling objects from above	-	-	-	-	opt
Heating with fan	-	-	-	-	std
Front sliding window under the roof	-	-	-	-	std
Removable lower front window	-	-	-	-	std
Right-hand side sliding window	-	-	-	-	std
Grab handles and "full wide" door handle to facilitate closing from the inside	-	-	-	-	std
Radio pre-arrangement	-	-	-	-	std
Windscreen wiper and washer on front window	-	-	-	-	std
Rearview mirror kit (right, left and rear) for cabin	-	-	-	-	opt
LED headlight kit (right, left and rear) for cabin	-	-	-	-	opt
HYDRAULIC SYSTEM					
ISO assisted hydraulic controls	mechanical	std	std	std	std
Gear pump / variable flow rate (std)	gear	std	std	std	std
Hydraulic arm swing control	pedal	joystick	pedal	pedal	pedal
Track adjustment control	std	std	std	std	std
Worklight positioned centrally under the arm	-	-	-	std	std
DIGGING AND MOVING EQUIPMENT					
Monobloc arm (length mm)	1350	1480	1650	1710	1710
Rocker arm (length mm)	700	870	950	985	1235
Long rocker arm	+200 mm (opt)	-	+250 mm (opt)	+250 mm (opt)	-
Arm hydraulic swinging angle	140°	130°	135°	70° / 55°	70° / 55°
Limit shock absorber on boom cylinder	std	std	std	std	std
Anti-Shock valve on arm cylinder	-	std	std	-	-
Rapid attachment of mechanical accessories	opt	opt	opt	opt	opt
Bucket in various dimensions	opt	opt	opt	opt	opt
HYDRAULIC CIRCUITS FOR ACCESSORIES					
Hydraulic circuit for hammer with direct return to tank for double-acting accessories	std	std	std	std	std
Second hydraulic circuit for double-acting accessories	-	-	-	opt	opt
SAFETY AND COMFORT					
Operating and travel controls lock out to enable the operator to exit	std	std	std	std	std
Single key for ignition, diesel tank cap and bonnet locks	std	std	std	std	std
Diesel tank cap with lock and mesh filter	-	std	std	std	std
Glass breaker hammer in the cabin	-	-	-	-	std
Turret lock automatic brake	std	std	std	std	std
Boom cylinder anti-drift system	-	-	std	std	std
Horn	std	std	std	std	std
External rear counterweight	-	-	opt	opt	-

HD09V5

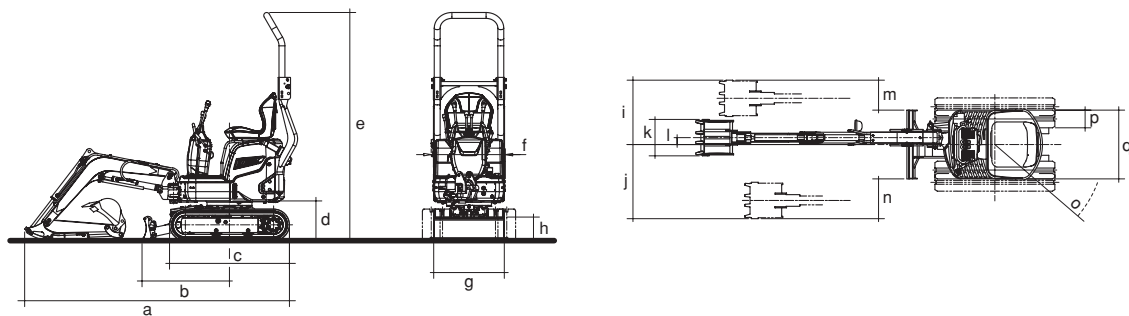

DIMENSIONS (mm)

a	b	c	d	e	f	g	h	i	j	k	l	m	n	o	p	q
2700	890	1220	390	2330	725	720/970	240	645	745	350	70	285	385	769	180	720/950

HD12VXE

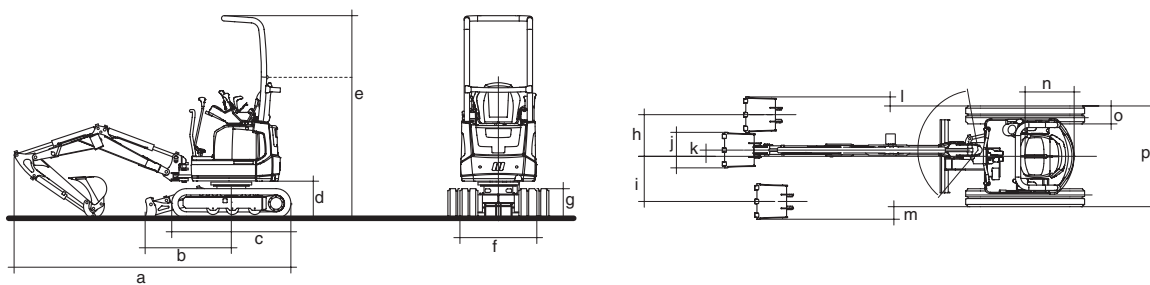

DIMENSIONS (mm)

a	b	c	d	e	f	g	h	i	j	k	l	m	n	o	p
3110	970	1339	417	2277 / 1700	870 / 1135	333	469	508	400	70	102	141	552	200	870 / 1135

HD17VXE

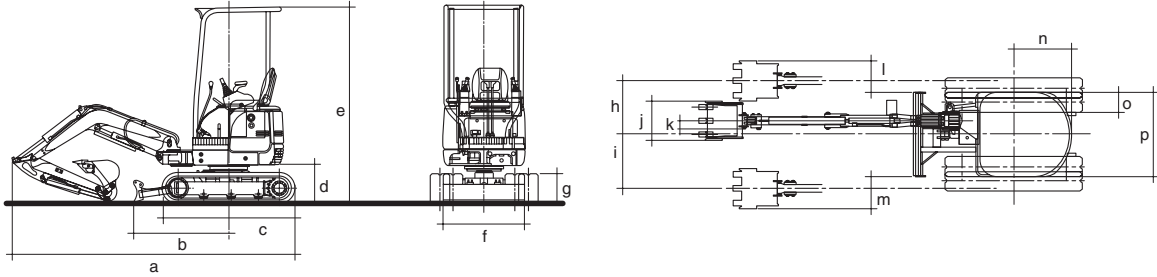

DIMENSIONS (mm)

a	b	c	d	e	f	g	h	i	j	k	l	m	n	o	p
3380	1155	1570	460	2330	980 / 1300	395	615	610	400	150	335	330	680	230	980 / 1300

HD18V5

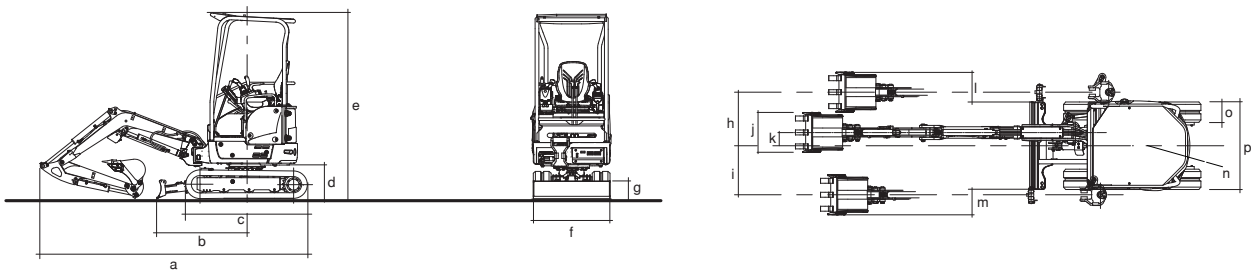

DIMENSIONS (mm)

a	b	c	d	e	f	g	h	i	j	k	l	m	n	o	p
3450	1160	1570	430	2390	990/1300	235	455	705	400	150	310	260	650	230	990/1300

HD20N5

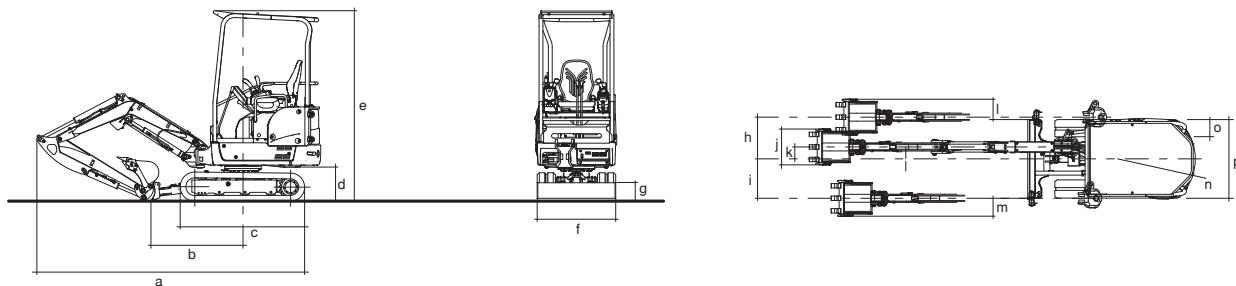

DIMENSIONS (mm)

a	b	c	d	e	f	g	h	i	j	k	l	m	n	o	p
3580	1160	1570	430	2400	990 / 1300	235	375	615	400	150	230	170	980	230	990 / 1300

working range

the drawing is generic and purely for illustrative purposes

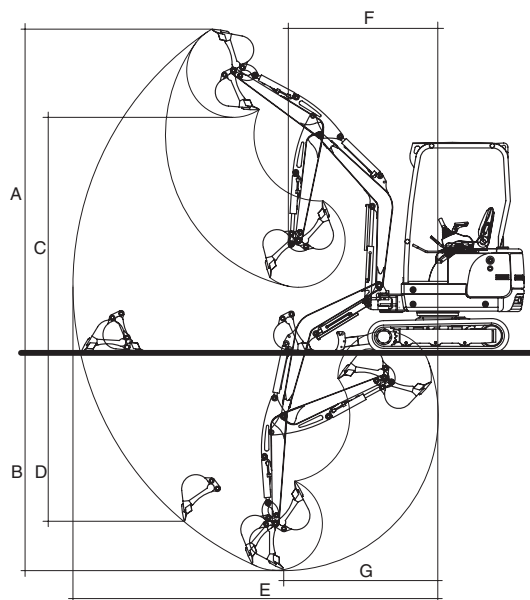

	HD09V5	HD12VXE	HD17VXE	HD18V5	HD20N5
A Maximum digging height	2750 / 2950* mm	3050 mm	3610 / 3810* mm	3610 / 3830* mm	3530 mm
B Max. digging depth	1570 / 1770* mm	2010 mm	2100 / 2350* mm	2190 / 2440* mm	2440 mm
C Maximum dumping height	1970 / 2150* mm	2170 mm	2560 / 2760* mm	2570 / 2780* mm	2520 mm
D Maximum vertical digging depth	1120 / 1400* mm	1480 mm	1770 / 2010* mm	1730 / 2040* mm	2020 mm
E Maximum digging radius	2980 / 3190* mm	3450 mm	3760 / 3990* mm	3820 / 4080* mm	3970 mm
F Minimum front turning radius	1220 / 1320* mm	1540 mm	1490 / 1580* mm	1480 / 1550* mm	1550 mm
with right arm swing	950 / 1030* mm	1290 mm	1280 / 1340* mm	1340 / 1410* mm	1430 mm
G Maximum digging depth radius	1330 / 1340* mm	1570 mm	1680 mm	1660 / 1660* mm	1560 mm

* with long arm



KATO IMER S.p.A.

53037 San Gimignano (SI) Loc. Cusona - Italy
Phone: +39 0577 951 21 - Fax: +39 0577 982 400
info@katoimer.com | www.katoimer.com